



> Upstream > Midstream > Downstream > Chemical valve applications



Fast track delivery

Special materials

Special design

L N G

Low temperature
and cryogenic
valve solutions



Your reliable valve partner

Red Point Alloys BV is global leader in tailor-made valves solutions and known for more than 25 years of experience in fast track delivery, special materials and special design.

With in-house engineering, production, assembling and testing, we are specialized in development and manufacturing of valves in a very limited time frame, according to our customer highest standards.

Our program covers standard valves in special and exotic materials as super-duplex, titanium, zirconium and nickel alloys – suitable for extraordinary applications – and special valves in common grades like carbon and stainless steels.

Flexible at all times, especially for emergency valve requirements.

With our highest level of quality, in-house production, technical know-how and dedicated staff, we look forward to be your perfect and reliable business partner in valves.



Low temperature and cryogenic services

Liquefied gases, such as liquid nitrogen and liquid helium, are used in many cryogenic applications. Liquid nitrogen is the most commonly used element in cryogenics and is purchasable around the world.

Liquefied natural gas (LNG) is natural gas that has been converted to liquid form for ease of storage or transport. At atmospheric pressure LNG has a temperature of minus 162°C (260°F) and mainly consist of methane. It contains ethane, propane, butane and nitrogen and has a higher density than natural gas (1/600th).

It is generally accepted in the industry that cryogenic temperature range starts at minus 150°C (238°F). In addition, certain gases are considered cryogenic because they take more than just an increase in pressure to compress their volume.

Red Point Alloys considers temperatures below minus 20°C (4°F) as low temperature service and less than minus 73°C (100°F) as cryogenic service and offers an extensive range of type tested valves.



Design & engineering

The Red Point Alloys low temperature and cryogenic valve program consist of ball, gate, globe, check and double block and bleed valves.

The valves are designed in accordance to industrial cryogenic standards like BS6364, MSS SP-134 and ISO28921-1, depending on customer requirement, service condition, material, pressure and temperature rating and other technical- or environment requirements.

Our engineering is equipped with state of the art software applications. Solid 3D Modeling, Finite Element Modeling And Post processing in order to build finite element models for strength analysis and Computational Fluid Dynamics software (CFD) is used for predicting and controlling fluid flow. CFD solutions give the power to model and simulate all fluid processes, including fluid-structure multiphysics.

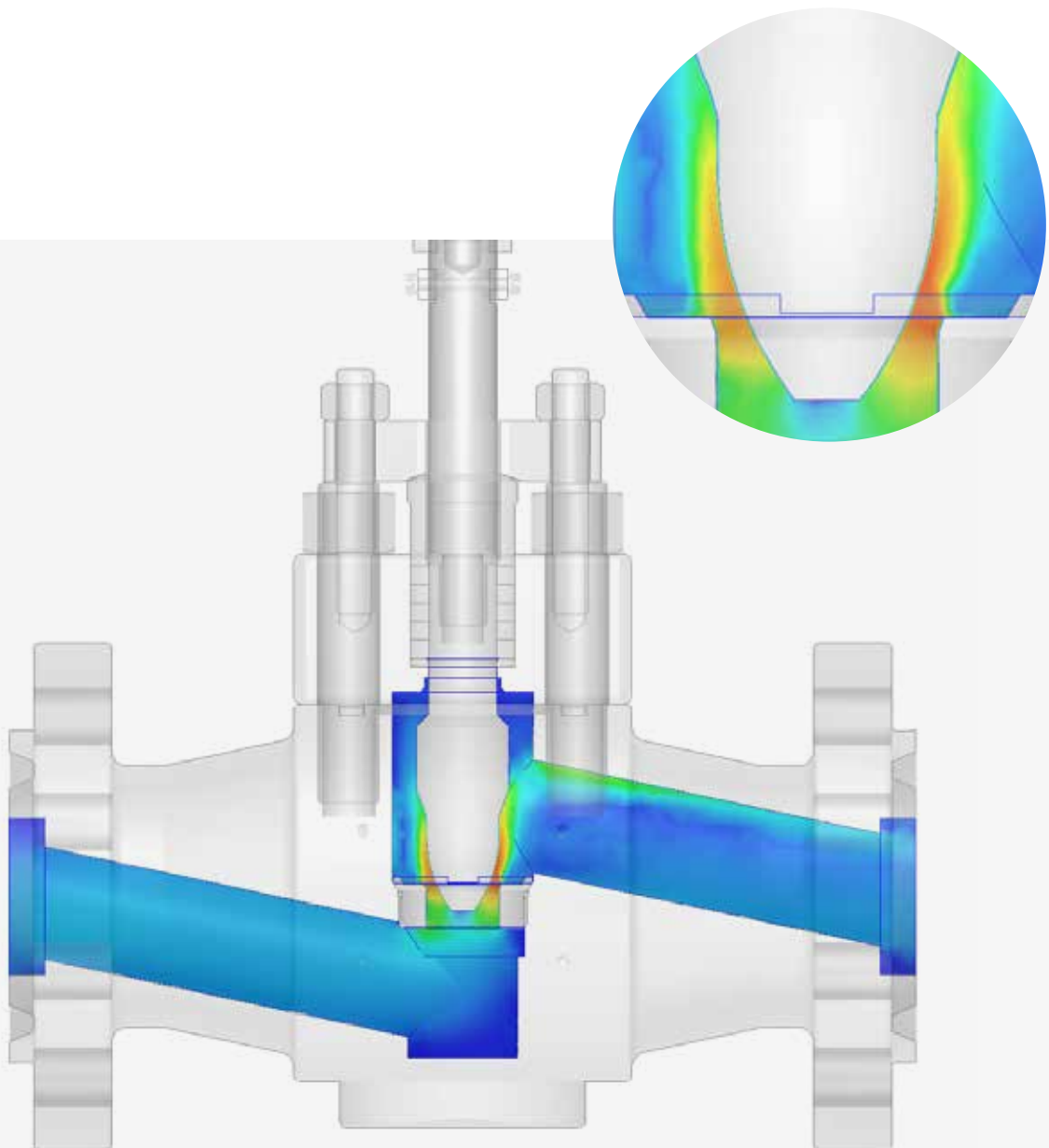

Testing

Red Point Alloys has a fully equipped in-house test facility in order to perform high and low pressure hydro-, gas-, and helium tests.

On all the low temperature and cryogenic valve designs a prototype approval test has been performed according to MESC SPE77/300.

These tests include operating cycles, measurements at ambient, high and low temperatures and Fugitive Emission testing both static and dynamic. After testing the valves are dismantled and individual parts are examined by an independent QA/QC inspector.

The end user is reassured the valves will perform optimally during their lifetime.

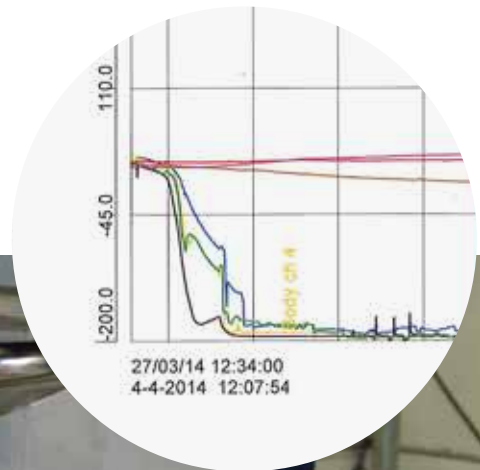

Materials for use in low temperature and cryogenic services

A wide range of valve component materials with ASME and EN standards are available, according to the tables as per below.

Temperature ratings according to EN12516-1 and ASME B16.34 standards. All other materials are available upon request. Materials to be used in cryogenic service shall meet relevant impact test requirements according to ASME B31.3 or EN 13480-2 standards.

Common used soft seat materials

Material	Temperature range
Virgin PTFE	-200 up to +260 (-328 up to +500)
TFM	-200 up to +260 (-328 up to +500)
RPTFE – 15 or 25% glass	-200 up to +260 (-328 up to +500)
PCTFE	-230 up to +175 (-382 up to +347)
DEVLON®	-196 up to +125 (-321 up to +257)*

* Long term service

Common used metal seat materials

API trim	Material	Seat	Disc	Other trim parts
2	304	304	304	304
5	410	Stellite	Stellite	410
9	Monel®	Monel®	Monel®	Monel®
10	316	316	316	316
12	316 / Hard faced	Stellite	316	316
13	Alloy 20	Alloy 20	Alloy 20	Alloy 20
14	Alloy 20 / Hard faced	Stellite	Alloy 20	Alloy 20
15	304 / Hard faced	Stellite	Stellite	304
16	316 / Hard faced	Stellite	Stellite	316
18	Alloy 20 / Hard faced	Stellite	Stellite	Alloy 20

All other trim materials available upon request

Available materials (Other materials upon request)

Steel grade	ASTM Forging	UNS Number	Werkstoffnummer
Carbon steel	ASTM A350 LF2	UNS K03011	WS 1.0508
Carbon steel	ASTM A350 LF3	UNS K32025	WS 1.5637
AISI 304	A182-F304	UNS S30400	WS 1.4301
AISI 304H	A182-F304H	UNS S30409	WS 1.4948
AISI 304L	A182-F304L	UNS S30403	WS 1.4306
AISI 310	A182-F310	UNS S31000	WS 1.4841
AISI 316	A182-F316	UNS S31600	WS 1.4401
AISI 316H	A182-F316H	UNS S31609	WS 1.4919
AISI 316L	A182-F316L	UNS S31603	WS 1.4404
AISI 316Ti	A182-F316Ti	UNS S31635	WS 1.4571
AISI 317	A182-F317	UNS S31700	WS 1.4449
AISI 317L	A182-F317L	UNS S31703	WS 1.4438
AISI 321	A182-F321	UNS S32100	WS 1.4541
AISI 321H	A182-F321H	UNS S32109	WS 1.4878
AISI 347	A182-F347	UNS S34700	WS 1.4550
AISI 347H	A182-F347H	UNS S34709	WS 1.4961
254 SMO	A182-F44	UNS S31254	WS 1.4529
AISI 2205	A182-F51	UNS S31803	WS 1.4462

Alloy	Trade Name	UNS Number	Werkstoffnummer
Alloy 20	Incoloy® 20	UNS N08020	WS 2.4660
Alloy 200	Nickel 200	UNS N02200	WS 2.4066/WS 2.4060
Alloy 201	Nickel 201	UNS N02201	WS 2.4061/WS 2.4068
Alloy 400	Monel®	UNS N04400	WS 2.4360
Alloy K500	Monel®	UNS N05500	WS 2.4375
Alloy 600	Inconel® 600	UNS N06600	WS 2.4816
Alloy 625	Inconel® 625	UNS N06625	WS 2.4856
Alloy 718	Inconel® 718	UNS N07718	WS 2.4668
Alloy X750	Inconel® X750	UNS N07750	WS 2.4669
Alloy 800	Incoloy® 800	UNS N08800	WS 1.4876
Alloy 800H	Incoloy® 800H	UNS N08810	WS 1.4958
Alloy 800HT	Incoloy® 800HT	UNS N08811	WS 1.4959
Alloy 825	Incoloy® 825	UNS N08825	WS 2.4858
Alloy B3	Hastelloy® B3*	UNS N10675	WS 2.4600
Alloy C276	Hastelloy® C276*	UNS N10276	WS 2.4819

* Hastelloy is a Haynes' US registered trademark

Cryogenic and low temperature valves

Features

- ✓ Depending on design, bonnet extensions are used in order to prevent gland/stem packing construction from freezing and operate within the optimum temperature of the packing
- ✓ Bonnet extensions with vapour space are used in order to prevent ice sticking affects during valve operation
- ✓ Preferable, bolted bonnets are used, so no welding required and easy access for maintenance purposes
- ✓ Both bolted bonnet-body and body-bodyflange closure construction with class A low emission Spiral Wound Gaskets
- ✓ If applicable, drip plate to protect isolation and prevent water to fall between valve and isolation

Technology

- ✓ Prior to assembly, valve components are deburred, cleaned and degreased using ultrasonic technologies
- ✓ Class A low emission stem packing from world leading packing manufacturers
- ✓ Valves have passed all required production tests as per applicable standard, specification and/or buyer description
- ✓ Cryogenic and low temperature tests are performed with Nitrogen gas and in accordance with customer specifications
- ✓ All test data is recorded and reports are available for valve data books
- ✓ All valves are conform fire safe design standards



Driplate
To protect isolation and preventing water to fall between valve and isolation



Stem packing
Class A low emission stem packing

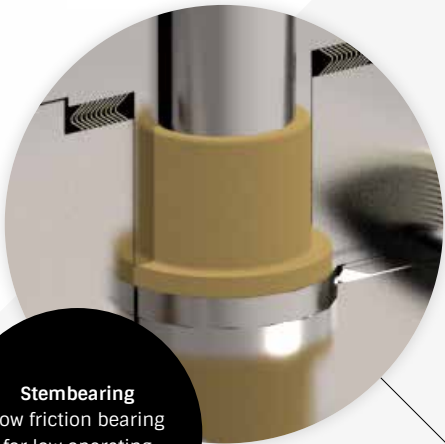

Stem bearing
Low friction bearing for low operating torques



FEATURES

Floating Ball valves



Glandplate construction for lower torques and accessibility packing adjustments

Stembearing for low operational torques



Small contact area between ball and seat for lower torques. Smaller ball to reduce pressure on seat. Better tightness at lower pressure

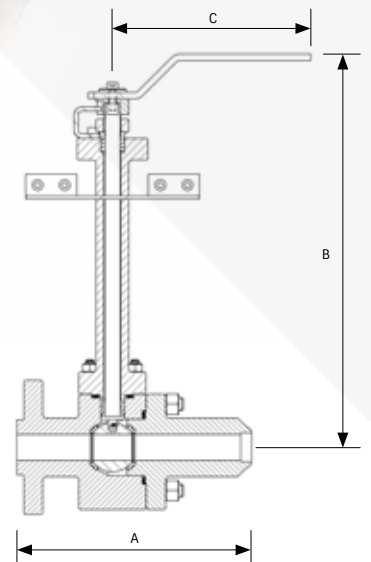

SIZE TABLE Floating Ball valves

Nominal pipe size	Pressure class	Face to Face / End to End											Minimum gas column	
		A		A		A		B		C				
		Flanged RF	Flanged RTJ	Flanged RTJ	Buttweld	Buttweld	Buttweld	Height	Height	Lever / handwheel	Lever / handwheel			
Inch	lbs	mm	Inch	mm	Inch	mm	Inch	mm	Inch	mm	Inch	mm	Inch	
1/2"	150	108,0	4,3	108,0	4,3	108,0	4,3	333	13,1	183	7,2	200	7,9	
1/2"	300	139,7	5,5	150,7	5,9	139,7	5,5	333	13,1	183	7,2	200	7,9	
1/2"	600	165,1	6,5	163,1	6,4	165,1	6,5	333	13,1	183	7,2	200	7,9	
3/4"	150	117,3	4,6	117,3	4,6	117,3	4,6	347	13,7	183	7,2	200	7,9	
3/4"	300	152,4	6,0	165,4	6,5	152,4	6,0	347	13,7	183	7,2	200	7,9	
3/4"	600	190,5	7,5	190,5	7,5	190,5	7,5	347	13,7	183	7,2	200	7,9	
1"	150	127,0	5,0	140,0	5,5	127,0	5,0	362	14,3	183	7,2	200	7,9	
1"	300	165,1	6,5	178,1	7,0	165,1	6,5	362	14,3	183	7,2	200	7,9	
1"	600	215,9	8,5	215,9	8,5	215,9	8,5	362	14,3	183	7,2	200	7,9	
1 1/2"	150	165,1	6,5	178,1	7,0	190,5	7,5	323	12,7	183	7,2	250	9,8	
1 1/2"	300	190,5	7,5	203,5	8,0	190,5	7,5	323	12,7	183	7,2	250	9,8	
1 1/2"	600	241,3	9,5	241,3	9,5	241,3	9,5	325	12,8	183	7,2	250	9,8	
2"	150	177,8	7,0	190,8	7,5	215,9	8,5	324	12,7	259	10,2	250	9,8	
2"	300	215,9	8,5	231,9	9,1	215,9	8,5	324	12,7	259	10,2	250	9,8	
2"	600	292,1	11,5	295,1	11,6	292,1	11,5	327	12,9	259	10,2	250	9,8	
3"	150	203,2	8,0	216,2	8,5	282,4	11,1	321	12,6	320	12,6	250	9,8	
3"	300	282,5	11,1	298,4	11,7	282,4	11,1	321	12,6	320	12,6	250	9,8	
3"	600	355,6	14,0	358,6	14,1	355,6	14,0	379	14,9	320	12,6	300	11,8	
4"	150	228,6	9,0	241,6	9,5	304,8	12,0	591	23,3	430	16,9	300	11,8	
4"	300	304,8	12,0	320,8	12,6	304,8	12,0	595	23,4	430	16,9	300	11,8	
4"	600	431,8	17,0	434,8	17,1	431,8	17,0	832	32,8	400*	15,7	300	11,8	
6"	150	393,7	15,5	406,7	16,0	457,2	18,0	810	31,9	400*	15,7	300	11,8	
6"	300	403,4	15,9	419,4	16,5	457,2	18,0	972	38,3	600*	23,6	300	11,8	

* Gearbox operated

FEATURES

Gate valves

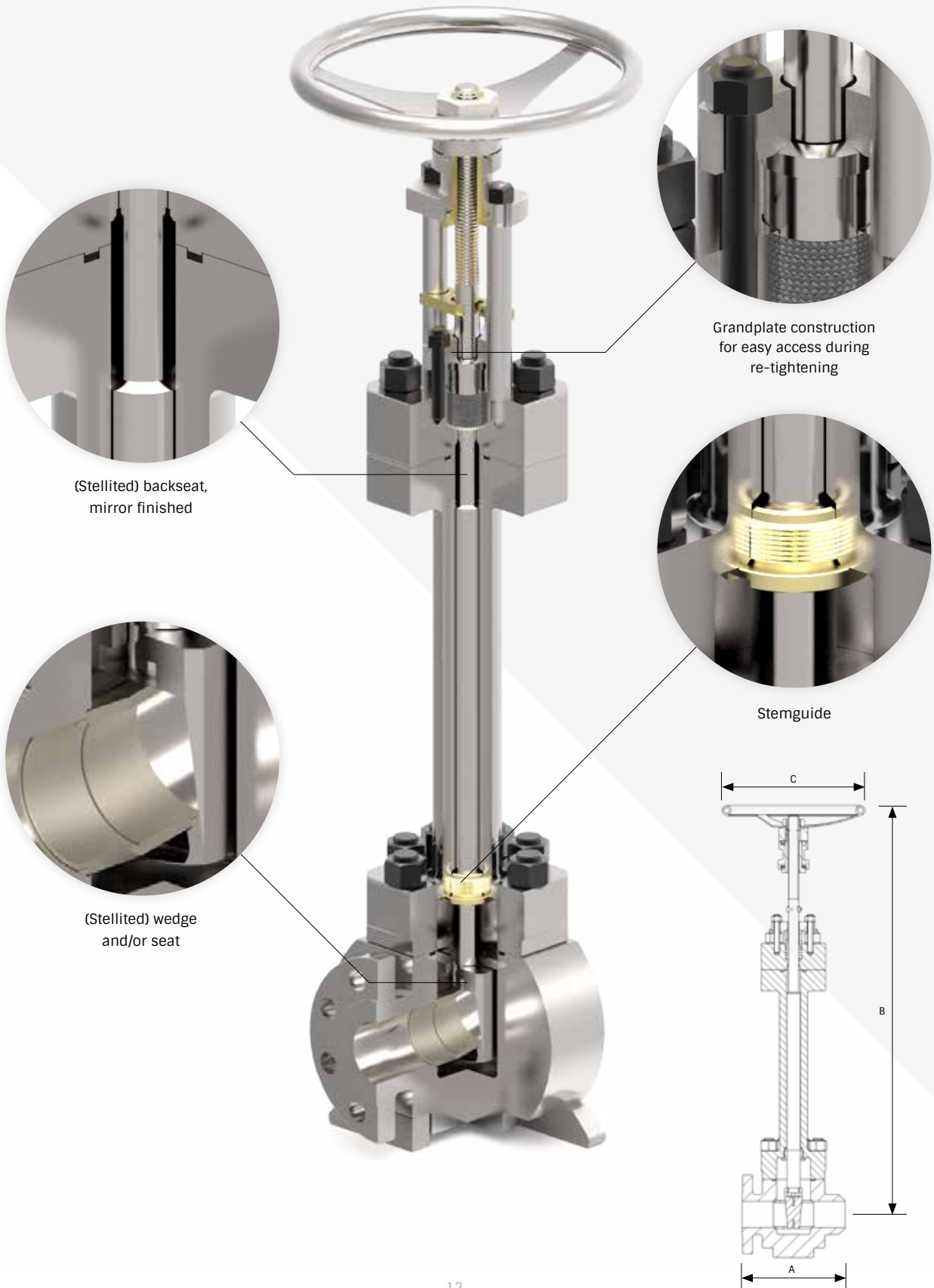

SIZE TABLE Gate valves

Nominal pipe size	Pressure class	Face to Face / End to End												Minimum gas column	
		A		A		A		A		B		C			
		Flanged RF	Flanged RTJ	Buttweld	Threaded and socket weld	Height	Handwheel	mm	Inch	mm	Inch	mm	Inch		
Inch	lbs	mm	Inch	mm	Inch	mm	Inch	mm	Inch	mm	Inch	mm	Inch	mm	Inch
1/2"	150	108,0	4,3	108,0	4,3	108,0	4,3	86	3,4	442	17,4	165	6	200	7,9
1/2"	300	139,7	5,5	150,7	5,9	139,7	5,5	92	3,6	442	17,4	165	6	200	7,9
1/2"	600	165,1	6,5	163,1	6,4	165,1	6,5	92	3,6	442	17,4	165	6	200	7,9
1/2"	900	215,9	8,5	215,9	8,5	215,9	8,5	100	3,9	442	17,4	165	6	200	7,9
1/2"	1500	215,9	8,5	215,9	8,5	215,9	8,5	100	3,9	439	17,3	165	6	200	7,9
1/2"	2500	263,7	10,4	263,7	10,4	263,7	10,4	•	•	533	21,0	300	12	200	7,9
3/4"	150	117,3	4,6	•	•	117,3	4,6	92	3,6	424	16,7	165	6	200	7,9
3/4"	300	152,4	6,0	165,4	6,5	152,4	6,0	92	3,6	424	16,7	165	6	200	7,9
3/4"	600	190,5	7,5	190,8	7,5	190,5	7,5	108	4,3	443	17,4	165	6	200	7,9
3/4"	900	228,6	9,0	228,6	9,0	228,6	9,0	127	5,0	439	17,3	165	6	200	7,9
3/4"	1500	228,6	9,0	228,6	9,0	228,6	9,0	127	5,0	439	17,3	165	6	200	7,9
3/4"	2500	273,1	10,8	273,1	10,8	273,1	10,8	•	•	531	20,9	300	12	200	7,9
1"	150	127,0	5,0	140,0	5,5	127,0	5,0	108	4,3	479	18,9	200	8	200	7,9
1"	300	165,1	6,5	178,1	7,0	165,1	6,5	108	4,3	479	18,9	200	8	200	7,9
1"	600	215,9	8,5	215,9	8,5	215,9	8,5	108	4,3	479	18,9	200	8	200	7,9
1"	900	254,0	10,0	254,0	10,0	254,0	10,0	130	5,1	548	21,6	300	12	200	7,9
1"	1500	254,0	10,0	254,0	10,0	254,0	10,0	130	5,1	548	21,6	300	12	200	7,9
1"	2500	307,8	12,1	307,8	12,1	307,8	12,1	•	•	552	21,7	400	16	200	7,9
1 1/2"	150	165,1	6,5	178,1	7,0	165,1	6,5	132	5,2	627	24,7	300	12	250	9,8
1 1/2"	300	228,6	9,0	203,5	8,0	190,5	7,5	152	6,0	685	27,0	300	12	250	9,8
1 1/2"	600	241,3	9,5	241,3	9,5	241,3	9,5	152	6,0	647	25,5	300	12	250	9,8
1 1/2"	900	304,8	12,0	304,8	12,0	304,8	12,0	166	6,5	643	25,3	300	12	250	9,8
1 1/2"	1500	304,8	12,0	304,8	12,0	304,8	12,0	166	6,5	643	25,3	300	12	250	9,8
1 1/2"	2500	384,0	15,1	387,0	15,2	384,0	15,1	•	•	745	29,3	400*	16*	250	9,8
2"	150	177,8	7,0	109,8	4,3	215,9	8,5	140	5,5	686	27,0	300	12	250	9,8
2"	300	215,9	8,5	231,9	9,1	215,9	8,5	170	6,7	690	27,2	300	12	250	9,8
2"	600	292,1	11,5	295,1	11,6	292,1	11,5	170	6,7	710	28,0	300	12	250	9,8
2"	900	368,3	14,5	371,3	14,6	368,3	14,5	190	7,5	692	27,2	400	16	250	9,8
2"	1500	368,3	14,5	371,3	14,6	368,3	14,5	190	7,5	692	27,2	400*	16*	250	9,8
2"	2500	450,9	17,8	453,9	17,9	450,9	17,8	•	•	891	35,1	600*	24*	250	9,8
3"	150	203,2	8,0	216,2	8,5	282,4	11,1	•	•	774	30,5	300	12	300	11,8
3"	300	282,4	11,1	298,4	11,7	282,4	11,1	•	•	774	30,5	300	12	300	11,8
3"	600	355,6	14,0	358,9	14,1	355,6	14,0	•	•	774	30,5	300	12	300	11,8
3"	900	381,0	15,0	384,0	15,1	381,0	15,0	•	•	1050	41,3	600*	24*	300	11,8
3"	1500	469,9	18,5	472,9	18,6	469,9	18,5	•	•	1100	43,3	600*	24*	300	11,8
4"	150	292,0	11,5	241,9	9,5	304,8	12,0	•	•	976	38,4	600*	24*	300	11,8
4"	300	305,0	12,0	320,8	12,6	304,8	12,0	•	•	974	38,3	600*	24*	300	11,8
4"	600	432,0	17,0	434,8	17,1	431,8	17,0	•	•	975	38,4	600*	24*	300	11,8
4"	900	457,0	18,0	460,2	18,1	457,2	18,0	•	•	1138	44,8	500*	20*	300	11,8
4"	1500	546,0	21,5	549,1	21,6	546,1	21,5	•	•	1138	44,8	500*	20*	300	11,8
6"	150	266,7	10,5	279,7	11,0	403,4	15,9	•	•	1266	49,8	600*	24*	350	13,8

Based on API 602 standard bore, except for 2500 lbs valves

* Gearbox operated

• Manufacturing standard

FEATURES

Globe valves

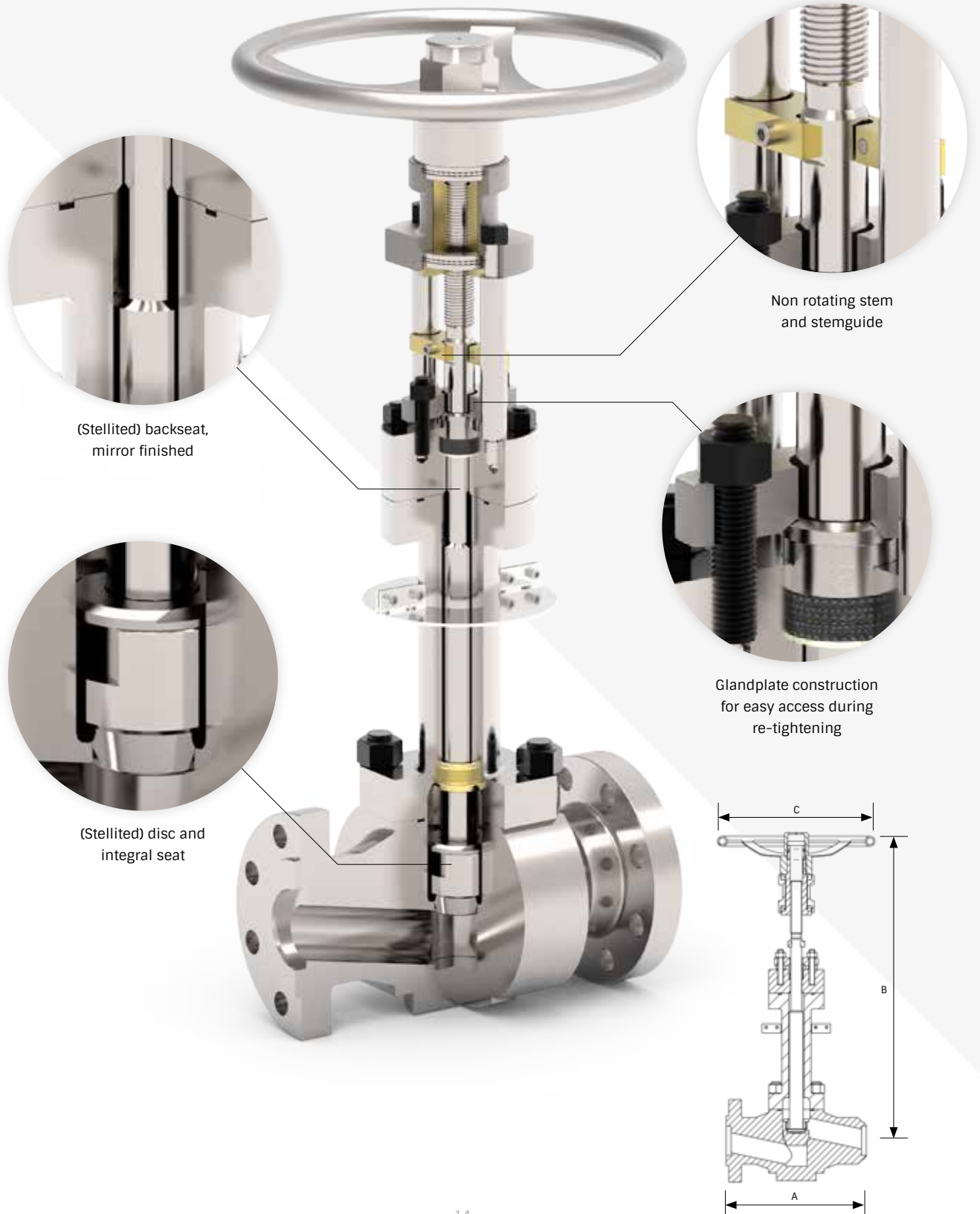

SIZE TABLE Globe valves

Nominal pipe size	Pressure class	Face to Face / End to End												Minimum gas column	
		A		A		A		A		B		C			
		Flanged RF	Flanged RTJ	Buttweld	Threaded and socket weld	Height	Handwheel								
Inch	lbs	mm	Inch	mm	Inch	mm	Inch	mm	Inch	mm	Inch	mm	Inch	mm	Inch
1/2"	150	108,0	4,3	•	•	108,0	4,3	86	3,4	402	15,8	165	6	200	7,9
1/2"	300	152,4	6,0	163,4	6,4	152,4	6,0	95	3,8	402	15,8	165	6	200	7,9
1/2"	600	165,1	6,5	163,4	6,4	165,1	6,5	95	3,8	402	15,8	165	6	200	7,9
1/2"	900	215,9	8,5	215,9	8,5	215,9	8,5	108	4,3	465	18,3	250	10	200	7,9
1/2"	1500	215,9	8,5	215,9	8,5	215,9	8,5	127	5,0	465	18,3	250	10	200	7,9
1/2"	2500	263,7	10,4	263,7	10,4	263,7	10,4	•	•	504	19,8	250	10	200	7,9
3/4"	150	117,3	4,6	•	•	117,3	4,6	95	3,8	405	15,9	165	6	200	7,9
3/4"	300	177,8	7,0	190,8	7,5	177,8	7,0	108	4,3	405	15,9	165	6	200	7,9
3/4"	600	190,5	7,5	190,8	7,5	190,5	7,5	108	4,3	413	16,3	200	8	200	7,9
3/4"	900	228,6	9,0	228,6	9,0	228,6	9,0	110	4,3	465	18,3	250	10	200	7,9
3/4"	1500	228,6	9,0	228,6	9,0	228,6	9,0	127	5,0	465	18,3	250	10	200	7,9
3/4"	2500	273,1	10,8	273,1	10,8	273,1	10,8	•	•	501	19,7	300	12	200	7,9
1"	150	127,0	5,0	140,0	5,5	127,0	5,0	108	4,3	452	17,8	200	8	200	7,9
1"	300	203,2	8,0	216,2	8,5	203,2	8,0	127	5,0	453	17,8	200	8	200	7,9
1"	600	215,9	8,5	215,9	8,5	215,9	8,5	127	5,0	460	18,1	250	10	200	7,9
1"	900	254,0	10,0	254,0	10,0	254,0	10,0	127	5,0	511	20,1	250	10	200	7,9
1"	1500	254,0	10,0	254,0	10,0	254,0	10,0	150	5,9	511	20,1	250	10	200	7,9
1"	2500	307,8	12,1	307,8	12,1	307,8	12,1	•	•	518	20,4	300	12	200	7,9
1 1/2"	150	165,1	6,5	178,1	7,0	165,1	6,5	146	5,8	576	22,7	250	10	250	9,8
1 1/2"	300	228,6	9,0	241,3	9,5	228,6	9,0	152	6,0	576	22,7	250	10	250	9,8
1 1/2"	600	241,3	9,5	241,3	9,5	241,3	9,5	152	6,0	587	23,1	250	10	250	9,8
1 1/2"	900	304,8	12,0	304,8	12,0	304,8	12,0	180	7,1	637	25,1	250	10	300	11,8
1 1/2"	1500	304,8	12,0	304,8	12,0	304,8	12,0	210	8,3	637	25,1	250	10	300	11,8
1 1/2"	2500	387,0	15,2	387,0	15,2	384,0	15,1	•	•	857	33,7	400*	16*	300	11,8
2"	150	203,2	8,0	216,2	8,5	203,2	8,0	159	6,3	592	23,3	300	12	250	9,8
2"	300	266,7	10,5	282,7	11,1	266,7	10,5	184	7,3	592	23,3	300	12	250	9,8
2"	600	292,1	11,5	295,1	11,6	292,1	11,5	184	7,3	592	23,3	300	12	250	9,8
2"	900	368,3	14,5	371,3	14,6	368,3	14,5	210	8,3	650	25,6	400	16	300	11,8
2"	1500	368,3	14,5	371,3	14,6	368,3	14,5	230	9,1	650	25,6	400	16	300	11,8
2"	2500	450,9	17,8	453,9	17,9	450,9	17,8	•	•	854	33,6	600*	24*	300	11,8
3"	150	241,3	9,5	254,3	10,0	241,3	9,5	•	•	748	29,4	400	16	250	9,8
3"	300	317,5	12,5	333,5	13,1	317,5	12,5	•	•	748	29,4	400	16	250	9,8
3"	600	355,6	14,0	358,6	14,1	355,6	14,0	•	•	798	31,4	400	16	300	11,8
3"	900	381,0	15,0	384,0	15,1	381,0	15,0	•	•	819	32,2	400*	16*	300	11,8
3"	1500	469,9	18,5	472,9	18,6	469,9	18,5	•	•	847	33,3	400*	16*	300	11,8
4"	150	292,0	11,5	305,1	12,0	292,0	11,5	•	•	750	29,5	400*	16*	300	11,8
4"	300	356,0	14,0	371,6	14,6	356,0	14,0	•	•	755	29,7	400*	16*	300	11,8
4"	600	432,0	17,0	434,8	17,1	432,0	17,0	•	•	786	30,9	400*	16*	300	11,8
4"	900	457,0	18,0	460,2	18,1	457,0	18,0	•	•	870	34,3	600*	24*	300	11,8
4"	1500	546,0	21,5	549,1	21,6	546,0	21,5	•	•	870	34,3	600*	24*	300	11,8
6"	150	406,4	16,0	419,4	16,5	406,4	16,0	•	•	993	39,1	600*	24*	300	11,8

* Gearbox operated
 • Manufacturing standard

FEATURES

Piston Check valves



(Stellited) disc
and/or seat

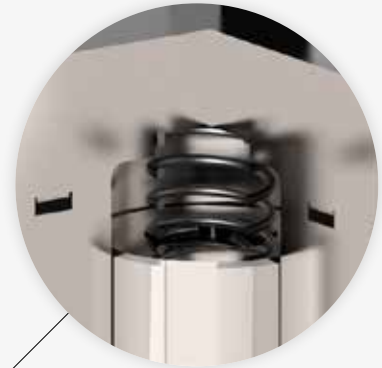

Spring actuated for
horizontal and vertical
mounting



Available in:

✓ Plug type disc

✓ Ball type disc

✓ Full ball

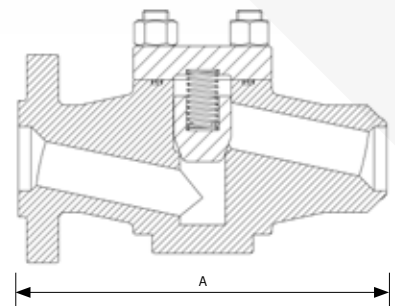

SIZE TABLE Piston Check valves

Nominal pipe size	Pressure class	Face to Face / End to End							
		A Flanged RF		A Flanged RTJ		A Buttweld		A Threaded and socket weld	
		Inch	lbs	mm	Inch	mm	Inch	mm	Inch
1/2"	150	108,0	4,3	•	•	108,0	4,3	86	3,4
1/2"	300	152,4	6,0	163,4	6,4	152,4	6,0	95	3,8
1/2"	600	165,1	6,5	163,4	6,4	165,1	6,5	95	3,8
1/2"	900	215,9	8,5	215,9	8,5	215,9	8,5	108	4,3
1/2"	1500	215,9	8,5	215,9	8,5	215,9	8,5	127	5,0
1/2"	2500	263,7	10,4	263,7	10,4	263,7	10,4	•	•
3/4"	150	117,3	4,6	•	•	117,3	4,6	95	3,8
3/4"	300	177,8	7,0	190,8	7,5	177,8	7,0	108	4,3
3/4"	600	190,5	7,5	190,8	7,5	190,5	7,5	108	4,3
3/4"	900	228,6	9,0	228,6	9,0	228,6	9,0	110	4,3
3/4"	1500	228,6	9,0	228,6	9,0	228,6	9,0	127	5,0
3/4"	2500	273,1	10,8	273,1	10,8	273,1	10,8	•	•
1"	150	127,0	5,0	140,0	5,5	127,0	5,0	108	4,3
1"	300	203,2	8,0	216,2	8,5	203,2	8,0	127	5,0
1"	600	215,9	8,5	215,9	8,5	215,9	8,5	127	5,0
1"	900	254,0	10,0	254,0	10,0	254,0	10,0	127	5,0
1"	1500	254,0	10,0	254,0	10,0	254,0	10,0	150	5,9
1"	2500	307,8	12,1	307,8	12,1	307,8	12,1	•	•
1 1/2"	150	165,1	6,5	178,1	7,0	165,1	6,5	146	5,8
1 1/2"	300	228,6	9,0	241,3	9,5	228,6	9,0	152	6,0
1 1/2"	600	241,3	9,5	241,3	9,5	241,3	9,5	152	6,0
1 1/2"	900	304,8	12,0	304,8	12,0	304,8	12,0	180	7,1
1 1/2"	1500	304,8	12,0	304,8	12,0	304,8	12,0	210	8,3
1 1/2"	2500	387,0	15,2	387,0	15,2	384,0	15,1	•	•
2"	150	203,2	8,0	216,2	8,5	203,2	8,0	159	6,3
2"	300	266,7	10,5	282,7	11,1	266,7	10,5	184	7,3
2"	600	292,1	11,5	295,1	11,6	292,1	11,5	184	7,3
2"	900	368,3	14,5	371,3	14,6	368,3	14,5	210	8,3
2"	1500	368,3	14,5	371,3	14,6	368,3	14,5	230	9,1
2"	2500	450,9	17,8	453,9	17,9	450,9	17,8	•	•
3"	150	241,3	9,5	254,3	10,0	241,3	9,5	•	•
3"	300	317,5	12,5	333,5	13,1	317,5	12,5	•	•
3"	600	355,6	14,0	358,6	14,1	355,6	14,0	•	•
3"	900	381,0	15,0	384,0	15,1	381,0	15,0	•	•
3"	1500	469,9	18,5	472,9	18,6	469,9	18,5	•	•
4"	150	292,0	11,5	305,1	12,0	292,0	11,5	•	•
4"	300	356,0	14,0	371,6	14,6	356,0	14,0	•	•
4"	600	432,0	17,0	434,8	17,1	432,0	17,0	•	•
4"	900	457,0	18,0	460,2	18,1	457,0	18,0	•	•
4"	1500	546,0	21,5	549,1	21,6	546,0	21,5	•	•
6"	150	406,4	16,0	419,4	16,5	406,4	16,0	•	•

Based on API 602 standard bore, except for 2500 lbs valves

• Manufacturing standard

FEATURES

Swing Check valves

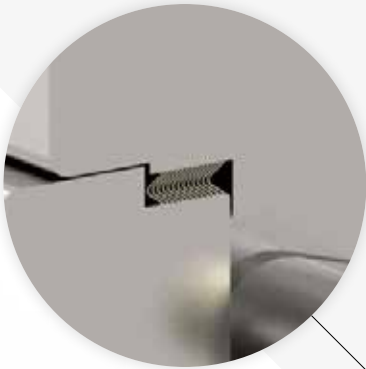

Class A low emission gasket



Enclosed hinge pin

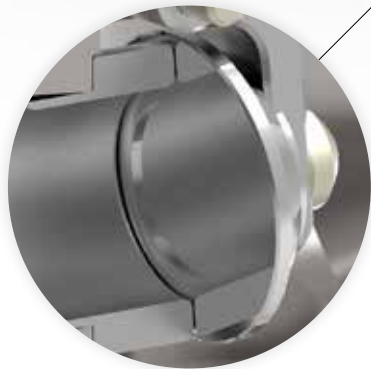
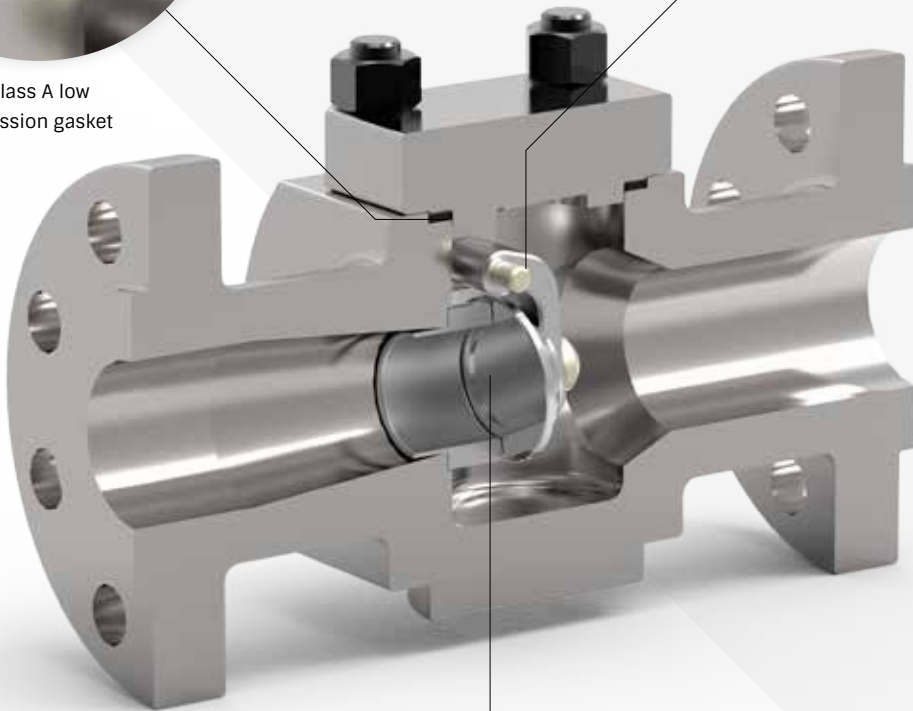

(Stellited) disc and/or seat

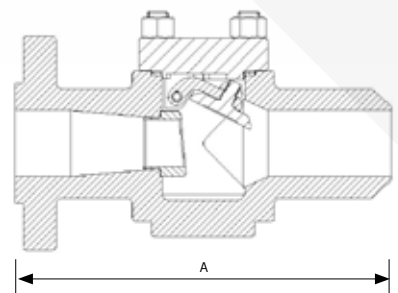

SIZE TABLE Swing Check valves

Nominal pipe size	Pressure class	Face to Face / End to End							
		A Flanged RF		A Flanged RTJ		A Buttweld		A Threaded and socket weld	
		mm	Inch	mm	Inch	mm	Inch	mm	Inch
1/2"	150	108,0	4,3	•	•	108,0	4,3	86	3,4
1/2"	300	152,4	6,0	163,4	6,4	152,4	6,0	95	3,8
1/2"	600	165,1	6,5	163,4	6,4	165,1	6,5	95	3,8
1/2"	900	215,9	8,5	215,9	8,5	215,9	8,5	108	4,3
1/2"	1500	215,9	8,5	215,9	8,5	215,9	8,5	127	5,0
1/2"	2500	263,7	10,4	263,7	10,4	263,7	10,4	•	•
3/4"	150	117,3	4,6	•	•	117,3	4,6	95	3,8
3/4"	300	177,8	7,0	190,8	7,5	177,8	7,0	108	4,3
3/4"	600	190,5	7,5	190,8	7,5	190,5	7,5	108	4,3
3/4"	900	228,6	9,0	228,6	9,0	228,6	9,0	110	4,3
3/4"	1500	228,6	9,0	228,6	9,0	228,6	9,0	127	5,0
3/4"	2500	273,1	10,8	273,1	10,8	273,1	10,8	•	•
1"	150	127,0	5,0	140,0	5,5	127,0	5,0	108	4,3
1"	300	215,9	8,0	228,9	8,5	215,9	8,0	127	5,0
1"	600	215,9	8,5	215,9	8,5	215,9	8,5	127	5,0
1"	900	254,0	10,0	254,0	10,0	254,0	10,0	127	5,0
1"	1500	254,0	10,0	254,0	10,0	254,0	10,0	150	5,9
1"	2500	307,8	12,1	307,8	12,1	307,8	12,1	•	•
1 1/2"	150	165,1	6,5	178,1	7,0	165,1	6,5	146	5,8
1 1/2"	300	241,3	9,0	241,3	9,5	241,3	9,0	152	6,0
1 1/2"	600	241,3	9,5	241,3	9,5	241,3	9,5	152	6,0
1 1/2"	900	304,8	12,0	304,8	12,0	304,8	12,0	180	7,1
1 1/2"	1500	304,8	12,0	304,8	12,0	304,8	12,0	210	8,3
1 1/2"	2500	387,0	15,2	387,0	15,2	384,0	15,1	•	•
2"	150	203,2	8,0	216,2	8,5	203,2	8,0	159	6,3
2"	300	266,7	10,5	282,7	11,1	266,7	10,5	184	7,3
2"	600	292,1	11,5	295,1	11,6	292,1	11,5	184	7,3
2"	900	368,3	14,5	371,3	14,6	368,3	14,5	210	8,3
2"	1500	368,3	14,5	371,3	14,6	368,3	14,5	230	9,1
2"	2500	450,9	17,8	453,9	17,9	450,9	17,8	•	•
3"	150	241,3	9,5	254,3	10,0	241,3	9,5	•	•
3"	300	317,5	12,5	333,5	13,1	317,5	12,5	•	•
3"	600	355,6	14,0	358,6	14,1	355,6	14,0	•	•
3"	900	381,0	15,0	384,0	15,1	381,0	15,0	•	•
3"	1500	469,9	18,5	472,9	18,6	469,9	18,5	•	•
4"	150	292,0	11,5	305,1	12,0	292,0	11,5	•	•
4"	300	356,0	14,0	371,6	14,6	356,0	14,0	•	•
4"	600	432,0	17,0	434,8	17,1	432,0	17,0	•	•
4"	900	457,0	18,0	460,2	18,1	457,0	18,0	•	•
4"	1500	546,0	21,5	549,1	21,6	546,0	21,5	•	•
6"	150	406,4	16,0	419,4	16,5	406,4	16,0	•	•

Based on API 602 standard bore, except for 2500 lbs valves

• Manufacturing standard

FEATURES

Dual Plate Check valves

Available in:

- ✓ Wafer, Lugged, Flanged, Buttweld and Hub End



Metal seated, hard faced and/or soft seated design



Various spring tension



Retainerless design

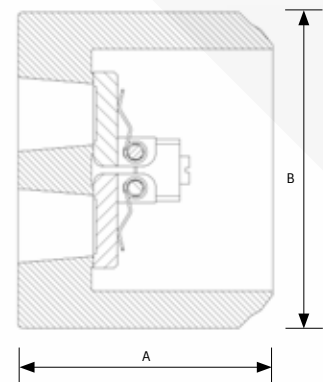

SIZE TABLE Dual Plate Check valves

Nominal pipe size	Pressure class	Face to Face / End to End						Diameter			
		A Wafer		A Lugged		A Buttweld		B Wafer		B Lugged	
		mm	Inch	mm	Inch	mm	Inch	mm	Inch	mm	Inch
2"	150	60,0	2,4	60,0	2,4	120,0	4,7	101,7	4,0	152,4	6,0
2"	300	60,0	2,4	60,0	2,4	120,0	4,7	107,9	4,2	165,1	6,5
2"	600	60,0	2,4	60,0	2,4	120,0	4,7	107,9	4,2	165,1	6,5
3"	150	73,0	2,9	73,0	2,9	146,0	5,7	133,4	5,3	190,5	7,5
3"	300	73,0	2,9	73,0	2,9	146,0	5,7	145,9	5,7	209,6	8,3
3"	600	73,0	2,9	73,0	2,9	146,0	5,7	145,9	5,7	209,6	8,3
4"	150	73,0	2,9	73,0	2,9	146,0	5,7	171,5	6,8	228,6	9,0
4"	300	73,0	2,9	73,0	2,9	146,0	5,7	178,0	7,0	254,0	10,0
4"	600	79,0	3,1	79,0	3,1	158,0	6,2	190,5	7,5	273,1	10,8
6"	150	98,0	3,9	98,0	3,9	196,0	7,7	219,1	8,6	279,4	11,0
6"	300	98,0	3,9	98,0	3,9	196,0	7,7	247,5	9,7	317,5	12,5
6"	600	136,0	5,4	136,0	5,4	272,0	10,7	263,5	10,4	355,6	14,0

Quality & Certificates

During the years, Red Point Alloys has obtained a wide range of qualifications, certifications and (customer) approvals.

Our valves are designed and manufactured against the latest industrial standards with proven designs. Our valve data books and design validation records are well documented. Quality is our philosophy.

All our employees are well educated, trained and fully aware that our products have to be of the highest quality level, which cannot be compromised in any way.

This is endorsed by the following certifications of our quality management system:

- NEN-EN-ISO9001: 2015
- PED directive 2014/68/EU annex III module H
- API spec Q and API-6D License
- CRN Registration OC05690.2
- Achilles JQS Qualification
- AD 2000 Merkblatt W0/A4 and TRD100
- OHSAS 18001: 2007
- TR CU 032
- TR CU 010
- Shell TAMAP approved
- ATEX 94/9/EC cat 2



Selection of supply history, cryogenic and low temperature services

Project: Karratha Gas Plant

Engineering

End-user

FLUOR



Scope of supply

- ✓ Ball valves, type: Double Block and Bleed
- ✓ Size: 3"
- ✓ Class: 300lbs
- ✓ Body material: A350-LF2



Project: Guntong Oil & Gas Field

Engineering

End-user



ExxonMobil

Scope of supply

- ✓ Non-return valves, type: Dual plate and Piston
- ✓ Size: 2 - 12"
- ✓ Class: 150 - 1500lbs
- ✓ Body material: CS



Project: Hannibal Plant

Engineering

End-user

Petrofac



BG TUNISIA
بج تونس



Scope of supply

- ✓ Globe valves
- ✓ Size: 1/2" - 1-1/2"
- ✓ Class: 300lbs
- ✓ Body material: SS316



Project: Jamnagar Refinery

Engineering

End-user

Linde

Reliance

Scope of supply

- ✓ Globe valves
- ✓ Size: 1" - 1-1/2"
- ✓ Class: 900lbs
- ✓ Body material: Alloy400



Project: Downstream service

Engineering

End-user



Scope of supply

- ✓ Non-return valves, type: Swing
- ✓ Size: 4"
- ✓ Class: 1500lbs
- ✓ Body material: Duplex F51



Project: Brage Platform

Engineering

End-user

AKER KVAERNER



Scope of supply

- ✓ Non-return valves, type: Dual plate
- ✓ Size: 3"
- ✓ Class: 150lbs
- ✓ Body material: 254SMO





Red Point

Fast track valve solutions



Red Point Alloys BV
International Head Office
Radonstraat 2
2718 TA Zoetermeer
The Netherlands
T +31 (0)79 363 20 70

info@redpoint.nl
www.redpoint.nl

Find us on  Facebook  LinkedIn  Twitter

Local Sales Office
Shanghai, PR China
T +86 21 61096125

Your contact / distributor: